



## Installation instructions

Vigilon Compact Plus panel based  
Fire detection and alarm system



up to 2km  
loop

## Contents

Notes	4	Mounting & cable entry points	20
Installation	4	How to surface mount the panel	20
Second fix	4	How to semi-flush mount the control panel	21
Fixture and fittings	4	Fitting the inner door	22
As fitted drawings	4	Cable termination on enclosure	23
Cable type and routing	4	Wiring test	23
Fire sensor covers	4	Mains supply	24
Earth continuity	5	Removable terminal block	25
Power supply	5	Terminals for external circuits on Master Control Board	25
Mains supply	5	Device loop circuits	26
Local Manual Call Point	5	Cable for wiring loop circuits	26
EN54 information	6	Loop wiring	26
Optional functions with requirements of European standard	6	Master alarm circuits	27
System wiring	7	Cable for wiring master alarm circuits	27
Cable separation	7	Clean contacts circuit	27
Lightning protection	7	Cable for wiring Clean contacts circuit	27
Cables for a Vigilon Plus system	8	Auxiliary relay circuits	28
Cable for wiring Mains Supply	8	Cable for wiring Auxiliary relay circuits	28
Cable for wiring system equipment	8	Wiring to Auxiliary relay contacts	28
Cable for wiring to RS232/RS485 ports	8	Monitored input circuit	29
Cable length	8	Cable for wiring Monitored input circuit	29
Loop cables	9	Wiring to Monitored input	29
Enhanced loop cables	9	USB Port	29
Standard loop cables	9	RS232 Ports	30
2.5mm <sup>2</sup> Loop cable (2.5Km loop)	9	Cable for wiring	30
Network cables	10	Connecting a thermal printer to RS232 Port	30
Enhanced Network cables	10	Repeat indicator panel	31
Standard Network cables	10	Copper Network	32
Loop circuit design	12	Vigilon Compact Plus Network	32
LOOP CARD	12	Network wiring	32
Condition of use of Loop Card	12	Network cable screen continuity	34
Vigilon Loop Diagnostic tool	12	How to minimise cross talk	35
Battery Standby & Loop load calculator	13	On completion of panel installation	36
Loop cable length	13	Other wiring	37
Loop device load and length calculations for 2Km loop card	13	FARE wiring requirements	37
What are Lumped and Distributed alarm device loads?	13	FPE wiring requirements	38
Distributed alarm device load	13	SAFE System Switch installation	39
Lumped alarm device load	13	S-Quad Sensor installation	40
Typical Vigilon Compact Plus System	14	Vigilon Compact Plus parts	45
Vigilon Compact Plus	15		
Features	15		
Technical data	16		
Control panel (CIE)	16		
Panel installation	19		

## Preface

This is the third issue of the Installation instructions for the Vigilon Compact Plus panel, it incorporates information relating to EN54 Part 13 and Type B compliance including SAFE System switch, Notified body and LVD updates.

These instructions must be read in conjunction with BS 5839 : Part 1, which is the Code of Practice for design, installation, commissioning and maintenance of systems in non-domestic premises.

## Associated Documents

- Vigilon Compact Plus panel based system - Operating instructions
- Log book

## Symbols on product



Electric shock hazard.



Protective Earth connection terminal.



The WEEE symbol. It indicates the product is to be recycled and not thrown away.



The CE compliance logo. This product is in conformity with the relevant European Union harmonisation legislation.

**RoHS** The RoHS compliance logo. The RoHS directive restricts the use of certain hazardous substances commonly used in electronic and electronic equipment.



The UKCA (UK Conformity Assessed) marking is a new UK product marking that is used for goods being placed on the market in Great Britain (England, Wales and Scotland).

## Conventions



This is a note to highlight important text that is normally hidden in the main text.



This is either a caution to prevent damage to the equipment or a warning to inform of dangerous conditions that may result in injury or death.

## Abbreviations

<i>ac</i>	<i>Alternating current</i>
<i>dc</i>	<i>Direct current</i>
<i>EOL</i>	<i>End of line</i>
<i>EP</i>	<i>Environmentally protected</i>
<i>ESD</i>	<i>Electrostatic discharge</i>
<i>FARE</i>	<i>Fire Alarm Routing Equipment</i>
<i>FPE</i>	<i>Fire Protection Equipment</i>
<i>I/F</i>	<i>Interface</i>
<i>IO or I/O</i>	<i>Input Output</i>
<i>IP</i>	<i>Ingress protection</i>
<i>LCD</i>	<i>Liquid crystal display</i>
<i>LED</i>	<i>Light emitting diode</i>
<i>LPCB</i>	<i>Loss prevention council certification board</i>
<i>MCB</i>	<i>Master control board (CARD 0)</i>
<i>MCP</i>	<i>Manual call point</i>
<i>MICC</i>	<i>Mineral insulated copper cable</i>
<i>N/C</i>	<i>Normally closed</i>
<i>N/O</i>	<i>Normally open</i>
<i>OC or O/C</i>	<i>Open circuit</i>
<i>PCB</i>	<i>Printed circuit board</i>
<i>PSU</i>	<i>Power supply unit</i>
<i>QB</i>	<i>Quick blow (fuse)</i>
<i>SC or S/C</i>	<i>Short circuit</i>
<i>T</i>	<i>Anti-surge (fuse)</i>

## Notes

The power-up of the control panel and commissioning of the system is done by the Servicing organisation.

### Installation

It is recommended that the installer follow the general requirements of *BS 5839 : Part 1 : 2017*, which is the code of practice relating to fire detection and alarm systems for buildings. The installer must follow the relevant parts of *BS7671 : 2008 Requirements for Electrical installations, IEE wiring regulations 17th edition* if installation is in the United Kingdom.

Where applicable the requirements of any national guidelines of the countries in which the product will be installed.

### Second fix

To prevent the possibility of damage or dirt degrading the performance or appearance of the products, the installation of second fix items should be delayed until all major building work in the area is complete.



**The installation of all outstanding parts and the panel power up is usually carried out during system commissioning.**

### Fixture and fittings

It is the installers responsibility to provide adequate fixtures and fittings for the type of construction surface onto which a product is to be installed, whilst utilising the fixing points on the respective product. As an aid to this decision, the weight and overall size of each full assembly together with implications on cable entries and routing should be taken into consideration.



**All these procedures assume that the cable, gland, steel box (BESA box) and other related accessories are provided by the installer. Also the cable glands used must meet the UL94V-1 or better flammability rating.**

### As fitted drawings

The installer should acquire site specific information from the interested parties, for details on the location of products for installation. The acquired information together with this guide and the relevant standards should be used to assist the work. Each product assembly can be identified from its package label. The contents of all packages should be checked for any discrepancies.

### Cable type and routing

Appropriate attention must be given to ensure the correct cable type is installed in accordance with 'as fitted drawings', site specific information and recommendations of *BS 5839 Part 1 : 2017*. The cables must be installed using cable manufacturers recommended fixing and accessories, see list of approved cables.

### Fire sensor covers

Each fire sensor may be supplied with a plastic dust cover. If supplied, the cover must be fitted to prevent dust and dirt from the building work contaminating the fire sensor.

### Earth continuity

All earth connection points should be clean to provide a good electrical conductivity path. To maintain the earth continuity: all earth leads and fittings provided should be installed. The loop cable screen must be continued through each system device on the loop circuit, whether the earth is connected to the device or not.



**Do not use any part of building structure for earthing.**

Some of the system products having metal enclosures have zinc coating around the cable termination points, the coating provides a good electrical conductivity path for cable earth termination. The zinc coating on metal enclosures should not be damaged. Any damage will expose bare metal, which can corrode and make a poor earth connection.

### Power supply

The power to the system is derived from the mains and battery supplies. Before removal of a card or disconnection of cable from the panel ensure both mains and battery supplies are disconnected.

### Mains supply

Mains supply to any fire alarm control and indicating equipment must be via an unswitched 5A fused spur unit. A disconnect device must be provided to disconnect both poles and must have a minimum gap of 3mm. The disconnect device should be available as part of the building installation and must be easily accessible after installation is complete.



**All mains powered equipment must be earthed.**

### Local Manual Call Point

To comply with the requirements of *EN54-2 : 1997* a conventional manual call point must be installed near the Control panel. The call point must be wired to the monitored line input of the control panel. During commissioning of the system the Command Build No 250 associated with the monitored line input must be set up to evacuate all sectors without delay.



**Failure to install and configure a local manual call point in the manner described above when delays are set up on the system will result in the panel not complying to *EN54-2 : 1997*.**

---

## EN54 information

### Optional functions with requirements of European standard

The Control panel complies with the requirements of *EN54-2 : 1997*. In addition to the basic requirements of the standard the panel conforms to the following optional clauses:

Clause	Description
7.8	Output to fire alarm devices
7.9	Control of Fire Alarm Routing Equipment FARE (options with requirements) sub clause: 7.9.1 Output to FARE
7.10	Output to Fire Protection Equipment FPE (options with requirements) sub clause: 7.10.1 Output Type A
7.11	Delays to action outputs
7.12	Dependencies on more than one alarm signal (options with requirements) sub clause: 7.12.2 Type B dependency 7.12.3 Type C dependency
8.3	Fault signals from point
9.5	Disablement of each addressable point
10	Test condition

## System wiring

If instructed, the installer may need to terminate as well as connect the cables to the appropriate terminal blocks.

### Cable separation

Where the outgoing and return cables of a loop circuit covers more than the equivalent of one zone they must not run together, for example, either close to the Control Panel or in a service duct. There should be as much physical separation as possible between the cables and the mechanical protection of the cable should be to a particularly high standard. This is to minimise the risk of accidental damage to both cables.

### Lightning protection

Where a loop cable is mounted to an external wall or between two buildings then consideration should be given to the use of lightning protection devices.

 **There must be a good earth connection to the voltage surge protection devices.**

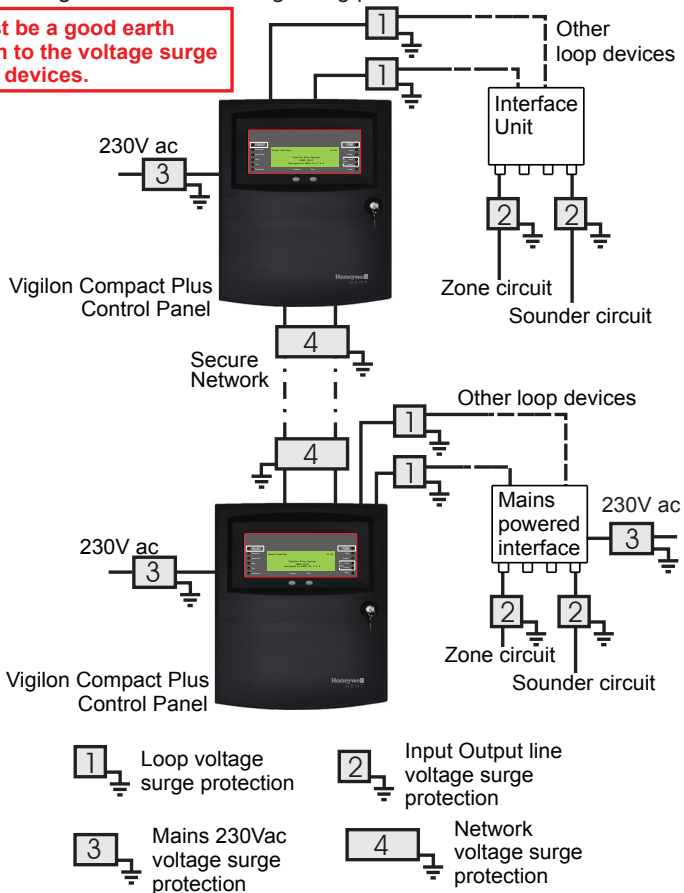

## Cables for a Vigilon Plus system

The British Standard BS 5839 Part 1 : 2017 Code of practice for system design, installation, commissioning and maintenance states the requirements for standard and fire resisting cables in Clause 26.2 sections d & e.

### Cable for wiring Mains Supply

The mains supply cable to Control and Indicating Equipment must be a standard fire resisting type and should meet PH30 classification.

### Cable for wiring system equipment

An approved cable must be used to wire system equipment to:

- Loop circuit
- Master alarm circuit
- Auxiliary relay circuit
- Input/output circuit and
- Mains supply.

An approved cable for wiring to these circuits is the:

- Mineral insulated cable (MICC) to BS6207:Part 1

For alternative cables refer to the complete list of alternative approved standard and enhanced cables for wiring system equipment, see “Loop cables” on page 9.

### Cable for wiring to RS232/RS485 ports

An approved cable must be used to wire to RS232 and RS485 ports.

The recommended cable for wiring to an RS232 port or an RS485 port is the:

- **Belden No 9729** (UL Style 2493)
  - 2 twisted pairs
  - Each pair individually screened 24AWG (7 strands x 32 AWG)
  - Capacitance between conductors 39.4pF/m at 1kHz
  - Capacitance conductor to screen 72.2pF/m at 1kHz
  - Temperature range -30°C to +60°C

For alternative cables refer to the complete list of approved standard and enhanced network cables for wiring to the RS232 / RS485 ports see “Network cables” on page 10.

### Cable length

The recommended length of cable for respective circuit:

- Upto 15m cable length for the wiring to RS232 port
- Upto 1.2Km cable length for the wiring to RS485 port

## Loop cables



**There is a maximum limit of 2Km loop cable usage allowed per loop circuit. This maximum limit is the sum of the cable used on main loop circuit, spurs off main loop circuit, plus cable runs to all input / output lines off loop powered interface units installed on the same loop.**

**There is a further maximum limit of 100m cable run allowed per input/output line off loop powered interface unit.**

The device loop cable carries both data and power, therefore its selection is important. Note the following:

- In countries where the European EMC directive is in force, only EMC Compliant cables are to be used.
- The loop cable usage must not exceed 2Km. This includes the cable used on main loop and spur circuits.
- Single pair cable must be used. It is NOT permissible to run mixed loops or outgoing and return pairs in a multi core cable, due to inadequate separation and possible electrical interference problems.
- Each core of the loop cable must be 1.5mm<sup>2</sup> cross section area.
- the cable screen must be capable of being earthed at each system device (outstation).
- Red is the preferred cover sheath for fire applications.
- The specified loop circuit cables are also suitable for wiring master alarm, auxiliary relay, input/output lines and mains supply.

## Enhanced loop cables

Approved cables for loop wiring (EMC Compliant)

- Draka Firetuf FT120 Enhanced - **FTPLUS2EH1.5RD** (formerly Firetuf **FT Plus**)
- Datwyler Pyrofil Enhanced
- Mineral insulated cable (MICC) to BS6207:Part 1
- Prysmian (previously Pirelli) **FP PLUS \***

## Standard loop cables

Approved cables for loop wiring (EMC Compliant)

- AEI Cables **FIRETEC \***
- Cavical SpA **FIRECEL SR 114H \*** distributed by Cables Britain
- Datwyler Pyrofil Standard \* (previously **LIFELINE**)
- Draka Firetuf EMC Standard 1.5mm<sup>2</sup> **FTEMC2EH1.5RDR**
- Draka Firetuf **FTES2EH1.5** (previously **FTZ2E1.5 FIRETUF OHLS \***) fire resistant data cable
- Huber & Suhner **RADOX FR \***
- Prysmian (formerly Pirelli) **FP200 FLEX \***
- Prysmian (formerly Pirelli) **FP200 GOLD \***
- Raydex **CDT FG950 \***

## 2.5mm<sup>2</sup> Loop cable (2.5Km loop)



**The cable reference for a 2.5mm<sup>2</sup> loop cable is similar to 1.5mm<sup>2</sup> cable, for example the cable reference for a Draka Firetuf 1.5mm<sup>2</sup> is FTPLUS2EH1.5 and for a 2.5mm<sup>2</sup> it is FTPLUS2EH2.5, consult cable supplier.**

For cables marked with an \* see note on the next page.



**The cables marked \* utilise laminated aluminium tape with a tinned drain wire for electrostatic screening. Under certain environmental conditions galvanic action may take place between the aluminium and the drain wire. This will severely degrade EMC performance as the foil to drain wire impedance will increase. Armoured variants of these can also be used for wiring a loop circuit.**

### Network cables

#### Enhanced Network cables

Approved cables for network wiring  
(EMC Compliant)

- Draka Firetuf FT120 Enhanced FTPLUS3EH1.5  
(Previously Firetuf FT Plus)  
1.2Km maximum Panel to Panel or Panel to Network node cable distance
  - 3 Cores, each having 1.5mm<sup>2</sup> cross section area
- **Mineral insulated copper cable**  
800m maximum Panel to Panel or Panel to Network node cable distance.
  - BS6207: Part 1
  - 3 parallel cores
  - having continuous metal sheath encapsulating
  - each core having 1.5mm<sup>2</sup> cross section area
  - a red cover sheath (preferred for alarm applications)
- Prysmian (formally Pirelli) **FP Plus\***  
1.2Km maximum Panel to Panel or Panel to Network node cable distance
  - 3 Cores each having 1.5mm<sup>2</sup> cross section area

#### Standard Network cables

Approved cables for network wiring  
(EMC Compliant)

- **Belden Armoured equivalent**  
This cable being a two pair cable to BS5308:Part 1 (type 2) 0.5mm<sup>2</sup> (16/0.2mm).  
600m maximum Panel to Panel or Panel to Network node cable distance.
- **Belden No 9729** (UL Style 2493)  
1.2Km maximum Panel to Panel or Panel to Network node cable distance
  - 2 twisted pairs
  - Each pair individually screened 24AWG (7 strands x 32 AWG)
  - Capacitance between conductors 39.4pF/m at 1kHz
  - Capacitance conductor to screen 72.2pF/m at 1kHz
  - Temperature range -30°C to +60°C
- **Belden No. 9842** EIA RS485 Applications, O/A Beldfoil® Braid  
1.2Km maximum Panel to Panel or Panel to Network node cable distance  
Must have following characteristics:
  - 2 twisted pairs
  - 24AWG (7 strands x 32 AWG) conductors
  - Characteristic impedance - 120ohms
  - Capacitance between conductors - 42pF/m at 1kHz
  - Capacitance conductor to screen - 75.5pF/m at 1kHz
- **Belden TR No. 89729**  
(Teflon jacketed)  
1.2Km maximum Panel to Panel or Panel to Network node cable distance
  - 2 twisted pairs
  - Each pair individually screened 24AWG (7 strands x 32 AWG)
  - Capacitance between conductors 39.4pF/m at 1kHz
  - Capacitance - conductor to screen

---

72.2pF/m at 1kHz

- Temperature range up to 200°C

▣ **Doncaster Cables Firesure Plus\***

1.2Km maximum Panel to Panel or  
Panel to Network node cable distance

- 4 Cores (2- pair plus earth)
- each core having 1.5mm<sup>2</sup> cross  
section area

▣ **Huber & Schner Radox series FR**  
communication cable\*

1.2Km maximum Panel to Panel or  
Panel to Network node cable distance

- 3 cores twisted triad screened
- 1.5mm<sup>2</sup> (7/0.42 stranded)  
conductors
- Nominal impedance 200 ohms  
(1KHz)
- Capacitance - conductors 110pF/m  
(1KHz)
- Capacitance - screen to core  
210pF/m (1KHz)
- Fire resistance tested to BS6387  
category CWZ and IEC 331.

▣ **Prismian (formally Pirelli)**  
**FP200 Flex\***

800m maximum Panel to Panel or  
Panel to Network node cable distance

- 3 Cores, each having 1.5mm<sup>2</sup> cross  
section area

▣ **Prismian (formally Pirelli)**  
**FP200 Gold\***

1.2Km maximum Panel to Panel or  
Panel to Network node cable distance

- 3 Cores
- each core having 1.5mm<sup>2</sup> cross  
section area

▣ **Prismian (formally Pirelli)**  
**FP 400 Armoured**

800m maximum Panel to Panel or  
Panel to Network node cable distance

- 4 Cores, each stranded 1.5mm<sup>2</sup>  
cross section area

## Loop circuit design



**It is important that redundancy is built into the system to accommodate for future expansions and change of area usage in the protected premises.**

The number of devices on a loop circuit can be limited by the total number of addresses available, the electrical load on the circuit, the maximum cable length and other geographical considerations.

- ▣ A loop circuit must not cover more than 10,000m<sup>2</sup> of floor area of a protected site
- ▣ In total a maximum of 200 devices are allowed per loop circuit.

### LOOP CARD

The panel is supplied with one Post March 2014 Loop Card (COMPACT-LPC-EN). If more than one loop is required then acquire additional cards for the second loop.

### Condition of use of Loop Card



**The Loop Card (COMPACT-LPC-EN) must never be fitted as a replacement card in a Vigilon Compact Plus panel where 3400 devices are installed on its loop circuits.**

- ▣ Up to 2Km loop length is possible with S4 and S3 Mark 2 devices installed on a loop circuit. In this case a rough method for calculating the loop load and loop cable length is shown in the leaflet for the loop card. For a precise loop load and battery standby calculation use the 'Battery Standby and Loop load calculator' tool.
- ▣ Up to 1Km loop length is possible with 34000 devices or a mix of 34000, S4 and S3 devices installed on a loop circuit. Again for precise loop load and battery standby calculation use the 'Battery Standby and Loop load calculator' tool.

## Vigilon Loop Diagnostic tool

The Vigilon Loop Diagnostic Tool can be used to diagnose loop circuits driven by Post March 2014 Loop Cards (COMPACT-LPC-EN) fitted in the panel, this is normally done during commissioning of the system.

# Battery Standby & Loop load calculator

Use the Battery Standby and Loop Load calculator tool to determine loop loading and standby capability of the Vigilon plus system.

The 'Battery standby and loop load calculator' tool can be downloaded from [www.gentexpert.co.uk](http://www.gentexpert.co.uk) website by registered users.

## Loop cable length

The loop cable length is defined as the sum of the length of cable used on the main loop plus that used on all the spur circuits off the main loop having system devices.

## Loop device load and length calculations for 2Km loop card

There can be up to 200 devices on a loop cable of up to 2Km length when using Loop Card (COMPACT-LPC-EN), where both device count and cable length are dictated by the number of alarm devices on the loop and how they are positioned, distributed or lumped together.

## What are Lumped and Distributed alarm device loads?

Example of Lumped alarm device load

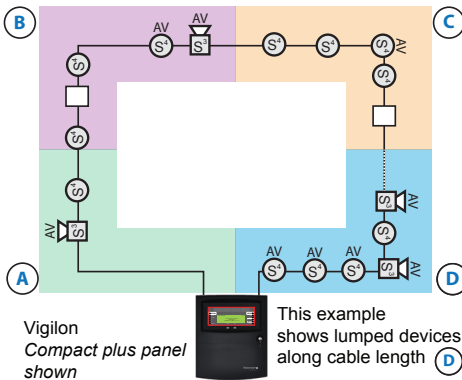

Where 35% of the alarm devices  are lumped together in 1/4 segment (A), (B), (C) or (D) of a loop.

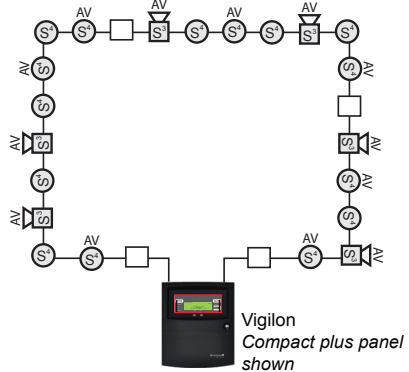

Example of Distributed alarm device load

Distributed alarm devices  are evenly spaced along the entire length of the loop cable from end to end.



key:		- Audio Visual S4 and S3 devices		- S4 Sensor only devices		- Other system devices
------	---	----------------------------------	---	--------------------------	---	------------------------

## Distributed alarm device load

Where the alarm load is distributed along the entire length of the loop using:

- 1.5mm<sup>2</sup> cable, the loop length can be up to 2Km with up to 200 devices
- 2.5mm<sup>2</sup> cable, the loop length can be up to 2.5Km with up to 200 devices.

## Lumped alarm device load





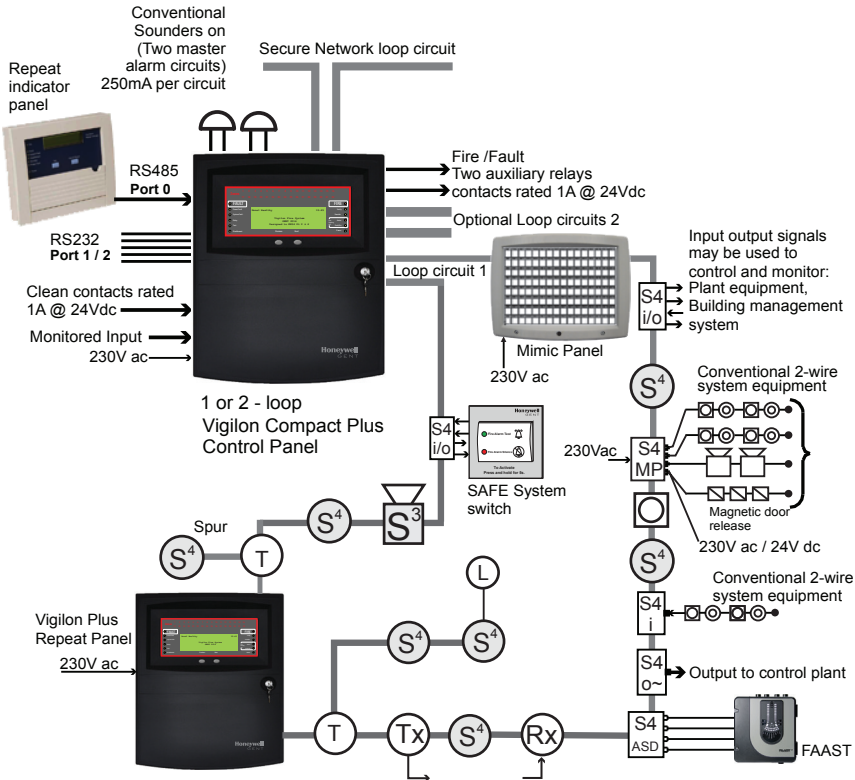

If the alarm devices are lumped together on a loop circuit then there is a trade off between the number of alarm devices and loop cable length possible, see also loop card leaflet which can be downloaded by registered users from [www.gentexpert.co.uk](http://www.gentexpert.co.uk).







# Typical Vigilon Compact Plus System

The loop allows wiring of addressable devices like **fire sensors, alarm sounders, call points, interface units, mimic and repeat panels**, a combined maximum of up to **200** devices are allowed per loop circuit, a further limit on a loop circuit is determined by device loading.







### Addressable System Devices

-  - S-Quad Sensor Speech Sounder & VAD
-  - S-Cubed Voice enhanced Speech, Sounder, VAD Unit
-  - Manual Call Point
-  - T Breaker
-  - Beam sensor Transmitter and receiver
-  - Beam sensor Transmitter and receiver

-  - S4 4-Input/Output loop powered interface
-  - S4 1-Input loop powered interface
-  - S4 1-Output + Confirmation input loop powered interface
-  - S4 Mains switching output loop powered interface
-  - S4 - Input/Output mains powered interface unit
-  - S4 - Input/Output ASD interface unit

### Conventional Products off interface ports

-  - Magnetic door release
-  - Alarm sounder
-  - Conventional Fire Detector
-  - Manual Call Point
-  - End of Line Unit

### LED off S<sup>4</sup> sensor

-  - Remote LED

# Vigilon Compact Plus



042cb/01

The Vigilant Compact Plus panel is designed to meet the requirements of *EN54-2 : 1997* and *EN54-4 : 1997*.

The panel can accommodate up to

2 loop circuits each up to 2Km in length that can have Vigilant analogue addressable devices, like fire sensors, manual call points, interface units and repeat panels. A number of Compact panels can be connected together on a secure network loop to give control and indication of network system events at any panel. The panel gives local visual and audible indications of system events, via indicators and message display. An integral mains derived power supply provides power to the panel and loops and the integral batteries provides a standby supply for up to 24 hours plus 0.5 hour alarm. A lockable front door prevents unauthorised access to the fire alarm controls. The panel is designed for both flush and surface mounting and facilitates both rear and top cable entry points.

## Features

- Analogue addressable fire detection and alarm control
- Supports up to two loop circuits each up to 2Km in length.
- Up to 200 addressable devices can be connected to a loop circuit, devices like sensors, call point, interface units, repeat and mimic panels
- Supports the connection of up to 31 panels in a secure loop network
- Two master alarm circuits
- RS485 (Port 0) to connect to repeat indicator panel(s)
- RS232 (Ports 1 and 2) to connect to external printer
- USB (Port 0) to connect to a Commissioning computer
- SD card for configuration and events logging.
- Two sets of auxiliary relay change over contacts configurable to operate with fire, fault or disablement event
- One set of clean voltage-free change over contacts that operate with master alarms
- Monitored input that actions a command build 250
- Standby supply to power the system via batteries for 24 hours plus 0.5 hour alarm load
- LCD with back light to display event information
- Integral 32 zone LEDs (with First fire flashing/steady options and an option to disable the integral zone indicators)
- LED lights for event indication
- Local audible buzzer for event announcement
- Push buttons for essential controls and menu driven commands
- Fire Alarm Routing Active and Fault/Disable LED indications
- Four programmable control buttons U1 to U4.

## Technical data

The Vigilon Compact Plus panel based system design has been carried out in accordance with a quality management system, which incorporates a set of rules for the design of all elements of the control and indicating equipment (CIE) and integral power supply equipment (PSE). The components of the control and indicating equipment and integral PSE have been selected for the intended purpose, and are expected to operate within their specification.

### Control panel (CIE)

<i>Standard</i>	<i>Designed to EN54-2:1997 + A1:2006 (and include optional clauses 7.8, 7.9, 7.9.1, 7.10, 7.10.1, 7.11, 7.12.2, 7.12.3, 8.3, 9.5 and 10)</i>
<i>Approval</i>	<i>LPCB approved</i>
<i>Panel dimensions in mm</i>	<i>height 403 x width 338 x depth 140</i>
<i>Panel weight</i>	<i>8.6Kg approximately without batteries 1 - 12V 12Ah battery - 4Kg (2 batteries are required)</i>
<i>Storage temperature</i>	<i>-10°C to +55°C</i>
<i>Operating temperature</i>	<i>0°C to +45°C</i>
<i>Relative Humidity</i>	<i>up to 90% (Non condensing) Temperature +5°C to +45°C</i>
<i>Emission</i>	<i>BS EN 6100-6-3 : 2001 Residential, Commercial &amp; Light Industry Class B limits</i>
<i>Immunity</i>	<i>BS EN50130-4 : 1996 Alarm systems: Electromagnetic compatibility Product family standard: Immunity requirements for components of fire, intruder and social alarm systems</i>
<i>Ingress Protection</i>	<i>IP31</i>
<i>Colour</i>	<i>Door and Backbox: HONEYWELL GREY 90 PMS BLACK C</i>
<i>Plug in Card Card 1 Card 2</i>	<i>1st Loop processor card LPC (supplied) 2nd Loop processor card (optional) and Network card (optional)</i>
<i>Devices per loop</i>	<i>A maximum of up to 200 addressable devices per loop</i>
<i>Device labels</i>	<i>Each device can be given a 32 character label for identification. Each MCP is restricted to 28 character label. Potentially up to 72 character label is possible depending on choice of words, tokenised words can lengthen the label.</i>
<i>Network Card</i>	<i>Supports the connection of up to 31 panels in a secure loop copper network, to give 1.2Km maximum between panels</i>
<i>Clean contacts</i>	<i>1 set of voltage free change over contacts rated 1A @ 24Vdc, active with master alarms</i>
<i>Monitored input</i>	<i>A closed input triggers a command build number 250. The input is normally open.</i>
<i>Auxiliary relays Aux relay 1</i>	<i>Voltage-free contacts rated 1A @ 24Vdc, 2 sets of change over contacts configured to operate immediately on a Fire event. The relay is normally de-energised</i>

Aux relay 2	<p>1 set of change over contacts configured to operate immediately on a Fault event. The relay is normally energised.</p> <p>The relays can be re-configured to operate with Fire, Fault or Disablement event, with a maximum delay of up to 10 minutes and can operate in a normally energised or de-energised state.</p>
Master alarm circuits voltage and current, protection fuses	<p>2 - (24 V nominal) 250 mA max per circuit  MA1 - FS1 T250mAH250V (20 x 5mm) on MCB board  MA2 - FS2 T250mAH250V (20 x 5mm) on MCB board</p>
Ports	<p>Port 0 and fuse RS485 -Repeat indicator panel (PB15) (Mode: <b>Repeat</b>) Includes a 24V supply protected by FS3 Fuse 200mA TE5 on MCB</p> <p>Port 1 and 2 RS232 -Printer (PB6) (Mode: <b>Std</b>, Printer, Universal or Ascom)</p> <p>Port 3 USB - (P16) Commissioning tool</p>
Baud	<p>The factory set baud rate for Port 0 it is <b>1200</b> and for Ports 1 &amp; 2 it is <b>38400</b>. Baud rate can be software reconfigured to another setting.</p>
Display	<p>Display - 8 lines by 40 character per line, back-lit, (Black characters on green background, liquid crystal display)</p>
Internal buzzer	<p>Announces Fire &amp; Fault events and key-press confirmation beep.</p>
Indicators	<p>Fire (red) 32, Zones (red) hidden till lit, Verify (amber), FARE Active (red), FARE Fault/Dis (amber), Power (green), Fault (amber), Disablement (amber), System fault (amber), Power fault (amber), Sounder (amber), Test (amber) and Delay (amber)</p>
Controls with the outer door closed, this is <b>Access level 1</b>	<p>Next and Previous buttons operable during Fire condition only</p>
Controls with the outer door open, this is <b>Access level 2a</b> (without Customer PIN)	<p>Sound Alarms, Silence Alarms, Reset, Cancel Buzzer, Verify, F1-F4 keys, Menu On/Off key, Numeric keys, U1-U2 keys available if configured to perform site specific actions by triggering of CB251 and CB252</p>
Controls with the outer door open, this is <b>Access level 2b</b>	<p>Access as level 2a plus access to complete level 2 menu commands with Customer PIN</p>
Controls with outer door open, this is <b>Access level 3</b>	<p>Access as level 2b plus access to complete level 3 menu commands with Engineer PIN</p>
Menus	<p>[Control], [Setup], [Information] and [Test Engineering] menus.</p>
Logs	<p><b>Active Logs:</b> Fire, Fault and Disablement  <b>Historic log:</b> All events  <b>Event logs:</b> Fault, Disablement, Warning, Supervisory, Exceptions and Historic fires. (up to 255 events)  <b>Fire Log</b> (up to 100 events)  NOTE: If an SD card is fitted in the Main Controller Card and it is enabled for Extended event logging, then for example a 1GB SD card can hold approximately 10 million events.  A larger size SD card can hold more events proportionally.</p>
24V supply	<p>FS3 T200mA (TE5) on MCB</p>

**Power supply**



**Always use the recommended replacement batteries, as there is a risk of an explosion if incorrect battery is used. Dispose of used batteries according to the manufacturer's instructions.**

COMPACT-PLUS panel	has an integral PSE model number VCS-PSU-24
Standard	Designed to EN54-4:1997 + A1:2002 and A2:2006
Mains supply voltage, fuse and Input current	230V +10% -15% 50Hz/60Hz protected by: FS3 T3.15AH250V Ceramic (20 x 5 mm) on PSU Input current - 0.6A
Nominal supply voltage for master alarm circuits	24V ± 4V
Battery circuit 'BAT1' fuse	FS1 T3.15A (TE5) on PSU board
PSU volts & fuses 43V (quiescent) 24V	On PSU board: FS6 T1A (TE5) FS4 T1A (TE5)
Battery	Batteries 2 x Powersonic 12V 12Ahr -(supplied), Model number: PS-12120 F1-FR. The batteries provide 24 hours standby power and 30 minutes alarm, determined by loop loading, use the Battery Standby and Loop Load calculator.
Lithium Battery	BATT3 on MCB. Type CR2032 3V cell. Replace only with the same or equivalent type battery.
Storage temperature	-10°C to +55°C
Operating temperature	0°C to +45°C
Relative Humidity	up to 90% (Non condensing) Temperature +5°C to +45°C
Indicators	<b>Left LED (yellow):</b> battery circuit 2 or 43V supply fault <b>Centre LED (yellow):</b> battery circuit 1, 24V supply <b>Right LED (green):</b> mains supply fault.
Maximum current drawn from the battery	3.15A with mains disconnected
EN54 Part 4 data	<i>I max a</i> 60mA at 43V (Output 1 – Loop current) 19 mA at 27.5V (Output 2 – Master Alarm + 24V DC output) 140mA - 215mA at 5V (Output 3 – Internal Board/Processor current)
	<i>I max b</i> 880mA at 43V (Output 1 – Loop current) 580mA at 27.5V (Output 2 – Master Alarm + 24V DC output) 186 mA - 225 mA at 5V (Output 3 – Internal Board/Processor current)
	<i>I min</i> 28mA at 43V (Output 1 – Loop current) 43mA at 27.5V (Output 2 – Master Alarm + 24V DC output) 25mA at 5V (Output 3 – Internal Board/Processor current)
UVLO	20.7V ± 0.4V
Max resistance of battery and associated wiring	1.3R
Primary DC output voltage	Output 1 43V ± 10% Output 2 (27.5V) 20.3V to 28.15V Output 3 5V ± 5% ripple voltage (peak to peak) <1% for all three output rails









**After panel power down hazardous voltages may still be present even when the indicators are extinguished.**

**Panel installation**

The Vigilon Compact Plus Panel is supplied in parts, it is important to check the contents of each package:



- ▣ Back box assembly
- ▣ Inner door assembly
- ▣ Outer door assembly
- ▣ 2 x 12V 12Ah Batteries

	Parts in the Spares pack	Qty
	Fuse T3.15AL250V 20mm x 5mm	1
	Fuse T3.15A (TE5)	2
	Fuse T1A (TE5)	2
	Fuse T200mA (TE5)	2
	10K Ohms Resistor	4
	Battery Link	1
	Battery Lead	1

Cardboard cover protecting the Master Control Board and Loop Card

Plastic cover protecting PSU

Product No: COMPACT-PLUS  
 Rated Voltage: 230V A.C.  
 Rated Current: 0.6A  
 Rated Frequency: 50Hz/60Hz  
 Mains Fuse: FS1 T3.15AL250V  
 Manufacture date: xx/xx/xx

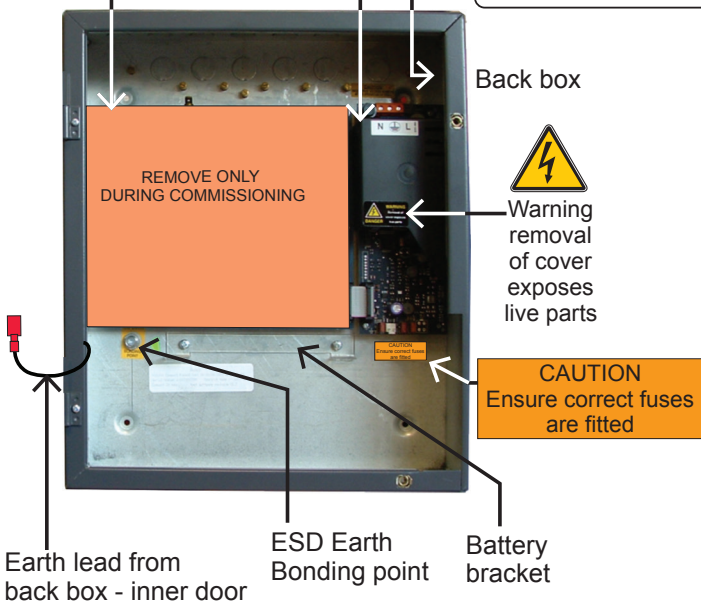

## Mounting & cable entry points

Any unused knockouts that have been removed should not be left open.

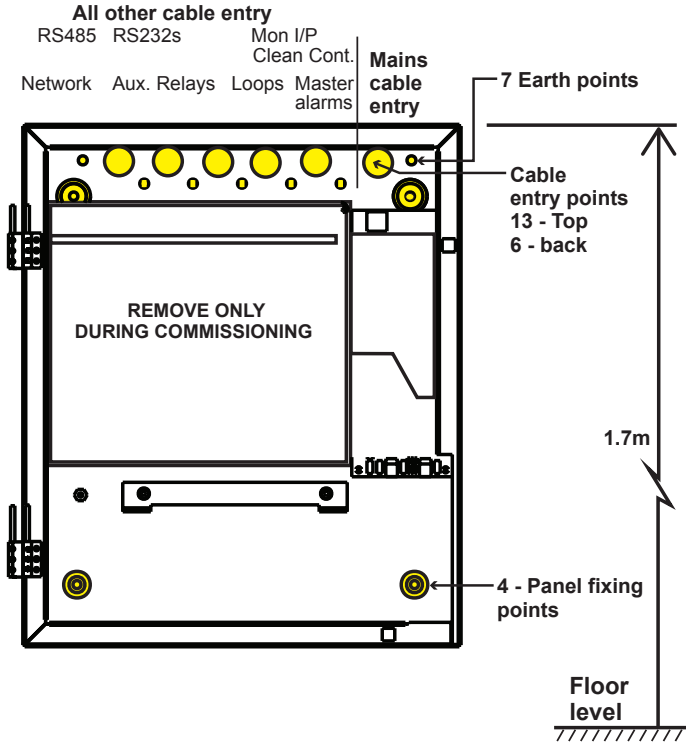

## How to surface mount the panel

Using the four fixing points mount the backbox onto a flat wall using suitable fixings.

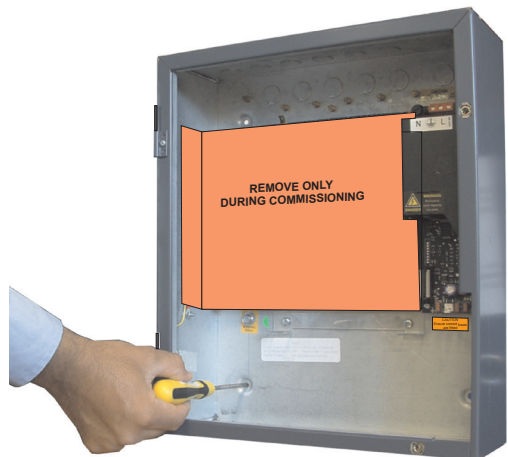

## How to semi-flush mount the control panel

The control panel may be semi-flush mounted using a flush surround (COMPACT-FLUSH).

A stainless steel flush surround is available as an option (COMPACT-FLUSH-SS) and if fitted it requires a stainless steel door (VIG-RPT-DOOR-SS).

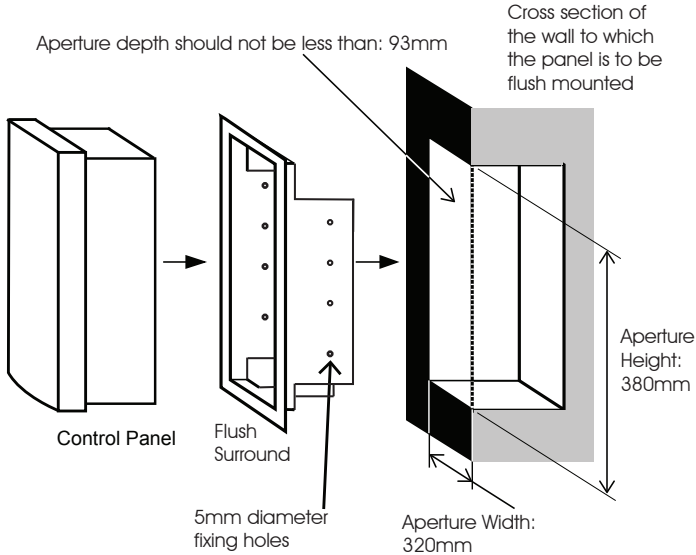

- Cut out an aperture in the wall to allow the flush surround to be fitted, see diagram for dimension of the aperture.
- Using the fixing holes on the flush surround, secure it into the aperture side walls.
- Knock out the appropriate top or rear cable points on the panel enclosure.
- Route the cables through the cable entry points into the panel and at the same time insert the panel into the flush surround.
- Fit the panel back box to the flush surround using the 4-off 5mm screws supplied with the flush surround.

## Fitting the inner door

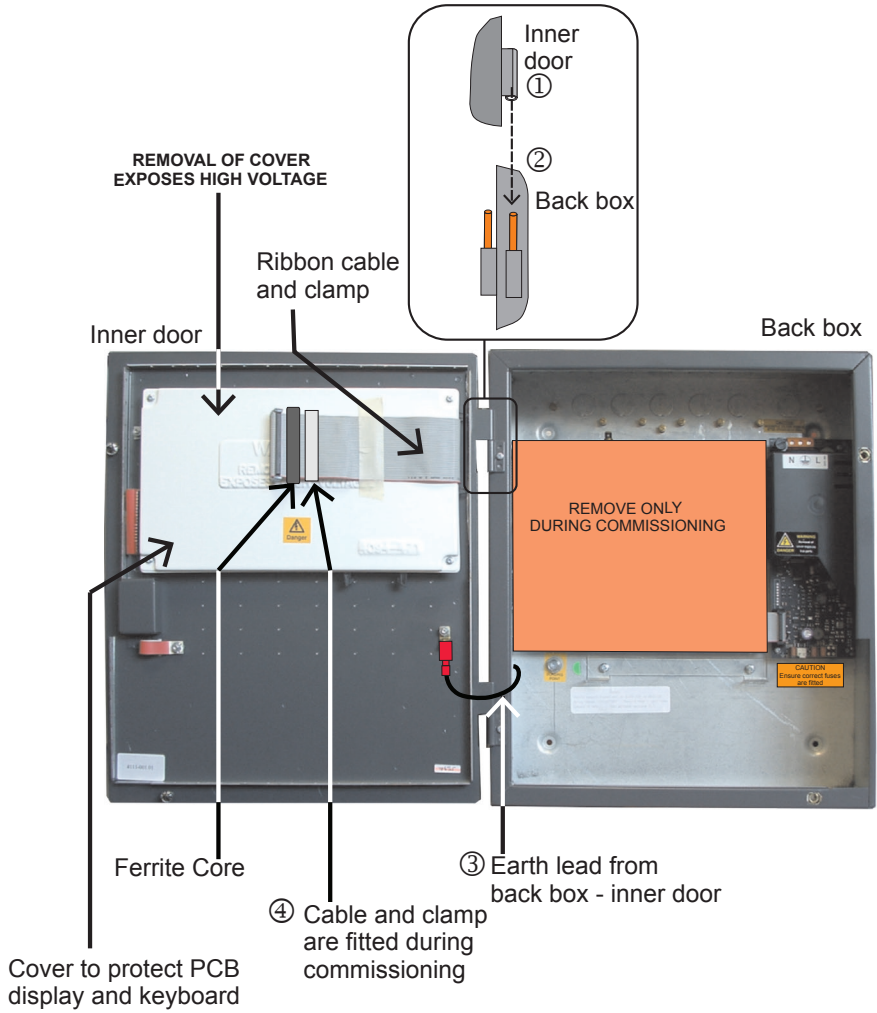

## Cable termination on enclosure

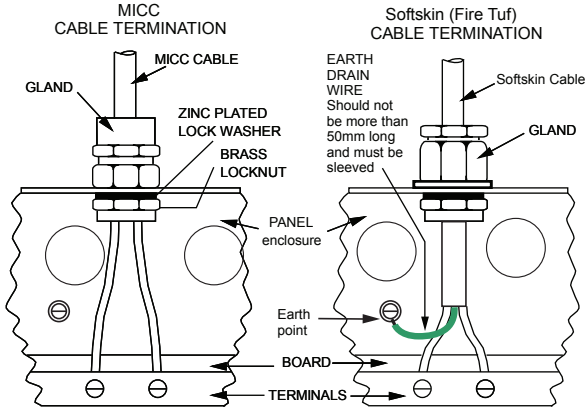

The wire length between the cable termination and point of connection must be as short as possible. Cable earth drain wire, where applicable, must be connected to the nearest earth point.

Terminate each cable at the dedicated entry point on the enclosure, using the cable manufacturers recommended techniques.

Where cables are not required to be connected leave **400mm** tail wire length (unless otherwise specified) and mark each **core** identifying its final point of connection. Where the cable is required to be connected, ensure it is secure to the respective terminal.

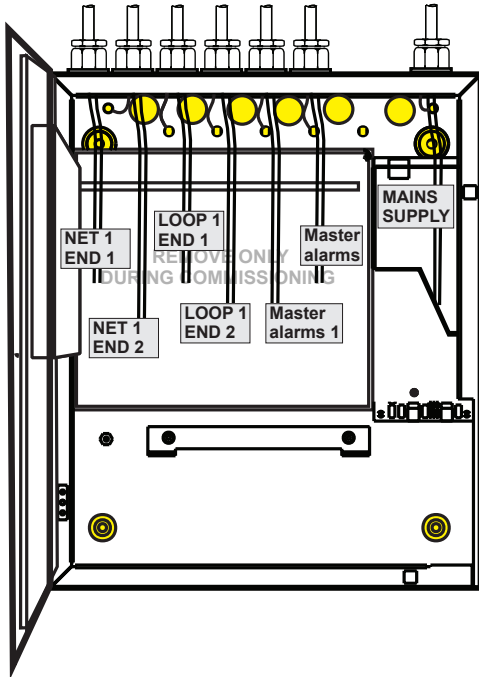

## Wiring test



**DO NOT** undertake high voltage insulation tests **WITH THE CABLES CONNECTED** to the panel and system device terminals. Such a test may damage the electronics circuitry in loop devices and at the panel.

## Mains supply



Ensure that the mains supply cable enters the panel through a dedicated cable entry, located adjacent to the mains terminal block and also ensure it is segregated from the loop wiring.



These fire alarm system products are not designed to be powered from IT Power systems.

All mains powered equipment must be earthed. The mains supply to the control panel must be via an unswitched 5A fused spur unit. A **disconnect device** must be provided to disconnect both poles and must have a minimum gap of 3mm. The disconnect device should be available as part of the building installation and must be easily accessible after the installation is complete.

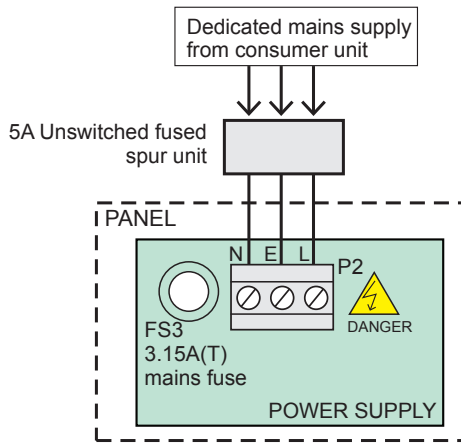

The fused spur isolator cover should be marked:

**FIRE ALARM - DO NOT  
SWITCH OFF**

The fire alarm equipment's fused spur unit must be fed from a dedicated switch or protective device at the local mains supply distribution board.

### Mains and battery supply connections

The mains and battery supply cables must be installed to the stage to facilitate the power up for commissioning, which is carried out by the Servicing organisation.



Where mains cable is to remain disconnected, its tail ends must be insulated to prevent dangerous conditions arising in the event of accidental switching On of the mains supply.

### Removable terminal block

To ease installation the terminal blocks on the Master Control Board can be unplugged from the board.

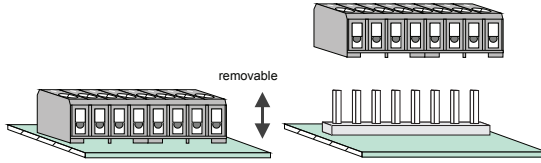

### Terminals for external circuits on Master Control Board

The Master Control Board (MCB) holds all the terminals for the connection of fire alarm loop circuits, master alarms, auxiliary relays, clean contacts, repeat indicator panel and monitored input.

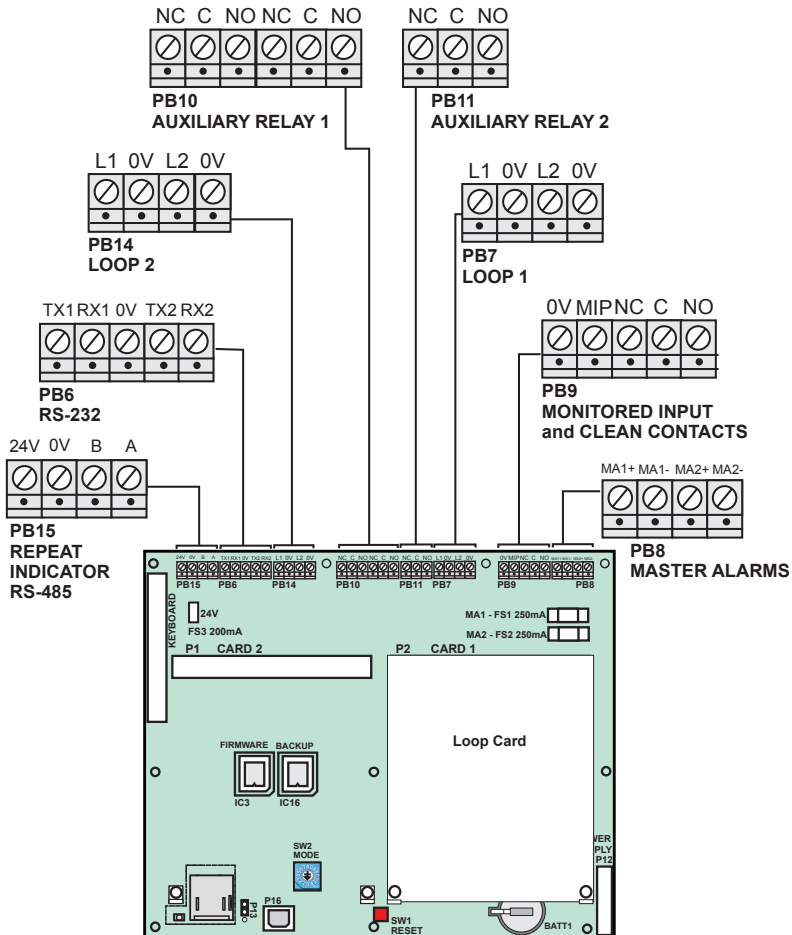

Master Control Board

**Device loop circuits**

The 2 loop circuits can each accept the connection of compatible addressable devices / outstations communicating on Vigilon 3217 protocol. Where a maximum of up to 200 devices / outstations are allowed per device loop circuit.

To maintain earth continuity on a loop, the loop cable screen must be continued through each system device, whether the earth is connected to a device or not.



**A loop circuit must not cover more than 10,000m<sup>2</sup> of floor area of a protected site.**

**A spur circuit must always be taken from the 'line common' terminals of a 3 ways device.**

**A spur must not cover more than the equivalent of one zone as defined in BS 5839 Part 1.**

**As every device has a loop isolator, the application of more than 32 devices does not require any special consideration.**

**Cable for wiring loop circuits**

An approved cable for wiring to these circuits is the Mineral insulated cable (MICC) to BS6207:Part 1. There are alternative approved standard and enhanced cables, see heading "Loop cables" on page 9.

**Loop wiring**

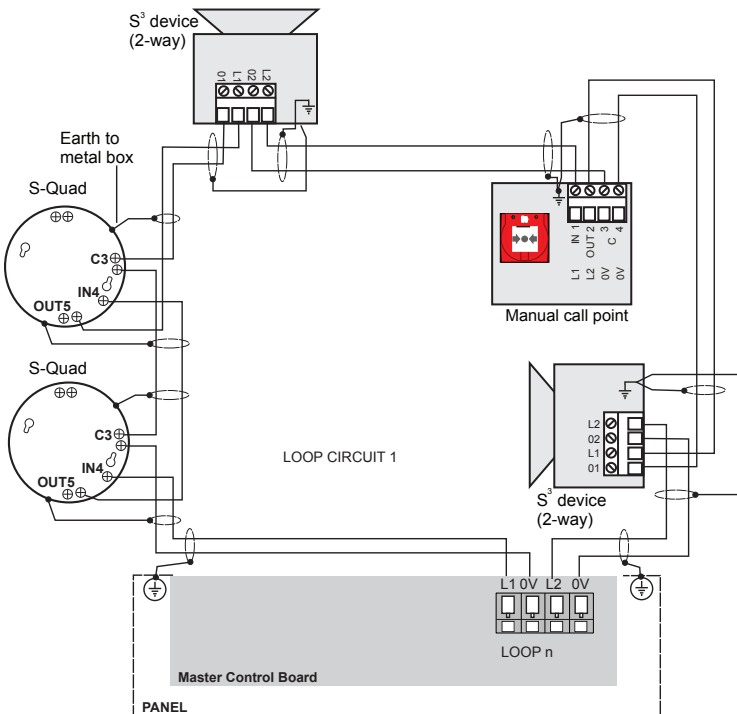

## Master alarm circuits

The two master alarm circuits accept the connection of conventional alarm sounders, such as conventional audio and visual alarm products. The two master alarm circuits must be interleaved for a compliant system.

### Cable for wiring master alarm circuits

An approved cable for wiring to these circuits is the Mineral insulated Cable (MICC) to BS6207:Part 1. There are alternative approved standard and enhanced cables, see heading "Loop cables" on page 9.

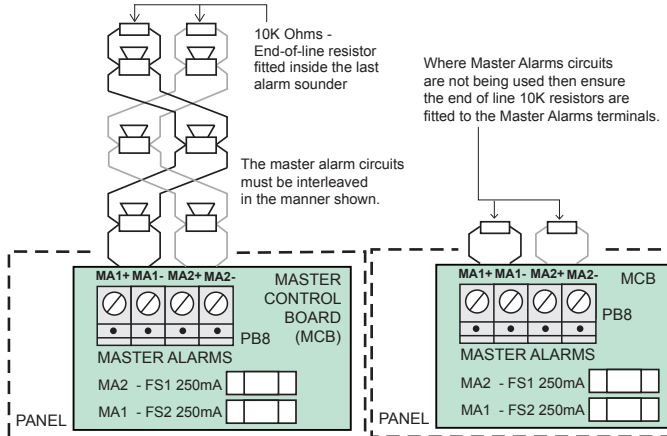

## Clean contacts circuit

The control panel operates the clean contacts relay when a fire event is received from the system. The clean contacts can be used to switch plant equipment, such as lift control system. If required, the contacts should be powered from an independent PSU.

### Cable for wiring Clean contacts circuit

An approved cable for wiring to this circuit is the Mineral insulated cable (MICC) to BS6207:Part 1. There are alternative approved standard and enhanced cables, see "Loop cables" on page 9.

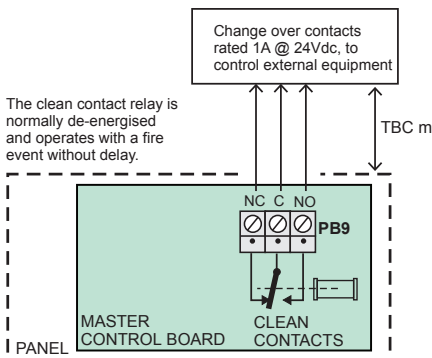

## Auxiliary relay circuits

The control panel operates the auxiliary contacts when the configured event is received from the system.

The auxiliary relays 1 and 2 contacts can be used to control external equipment, such as an automatic dialer that makes the call for fire fighting action. The relays can be individually re-configured to operate with either fire, fault or disablement event in the system.

The relay operation can also be delayed by up to 10 minutes and can be set up to operate in a normally energised or de-energised state. The contacts should be powered from an independent power supply, where required.

### Cable for wiring Auxiliary relay circuits

An approved cable for wiring to these circuits is the Mineral insulated cable (MICC) to BS6207:Part 1. There are alternative approved standard and enhanced cables, see "Loop cables" on page 9.

### Wiring to Auxiliary relay contacts

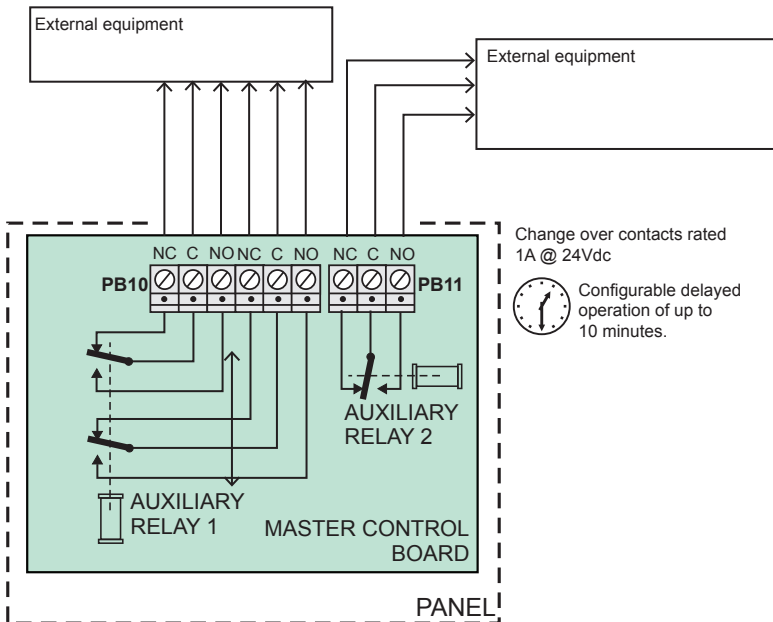

Factory default:

Aux relay 1 is normally de-energised and operates with a fire event without delay.

Aux relay 2 is normally energised and operates with fault event without delay.

**Note:** Aux relay 2 has been shown in the above diagram in its de-energised state, which is the state when there is no power to the panel.

## Monitored input circuit

This may be used for class change application in schools. The monitored input at the fire panel is activated by an external switch installed a maximum of up to 100m cable distance away from the panel.

The input is monitored for both short and open circuit fault. When the input is active it triggers a command build number 250 of the fire panel. The command build action is configured during the commissioning of the system. For example the action can be to sound the alarms of the system for the duration the push button is pressed.

## Cable for wiring Monitored input circuit

An approved cable for wiring to these circuits is the Mineral insulated cable (MICC) to BS6207:Part 1. There are alternative approved standard and enhanced cables, see "Loop cables" on page 9.

## Wiring to Monitored input

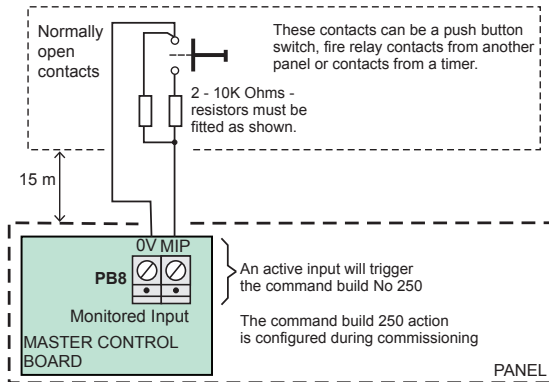

## USB Port

The Port 3 is a USB port that is used to connect to the commissioning tool. This tool allows ease of configuring the system.

PORT 3 is the USB port that can be accessed through connector P16 of the Master Control Board (Card 0)

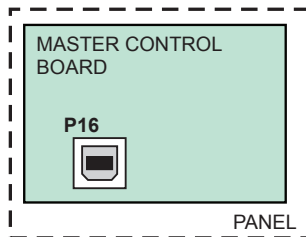

## RS232 Ports

The ports 1 and 2 of the fire panel offer RS232 communication, having configurable modes of operation and baud rate which are set during the commissioning of the system. The configurable modes include, standard (default), printer, universal or Ascocom. The ports can be used to connect an external printer or commissioning tool.

### Cable for wiring

An approved cable to wire to RS232 and RS485 ports is the:

■ **Belden No 9729** (UL Style 2493)

- 2 twisted pairs
- Each pair individually screened 24AWG (7 strands x 32 AWG)
- Capacitance between conductors 39.4pF/m at 1kHz
- Capacitance conductor to screen 72.2pF/m at 1kHz
- Temperature range -30°C to +60°C

For alternative standard and enhanced cable for wiring to the RS232 port, see "Network cables" on page 10.

### Connecting a thermal printer to RS232 Port

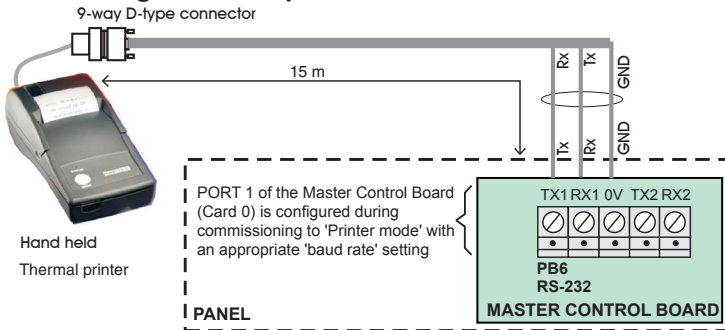

## Repeat indicator panel

Up to four repeat indicator panels can be connected directly to the fire panel at Port 0.

The furthest repeat indicator panel can be installed a maximum of 1.2Km cable distance away from the fire panel.

The Control panel's Port 0 is configured for Repeat mode and is set up for RS485 communication and the baud rate is selected during the commissioning stage.

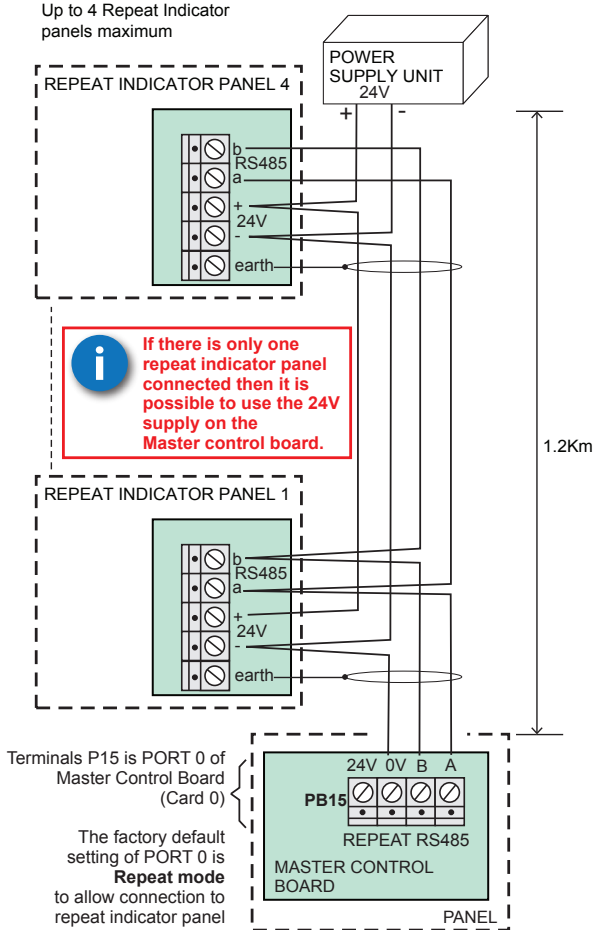

# Copper Network



**In countries where the European EMC directive is in force use only those cables that are EMC Compliant, see list under the heading Network cables.**

## Vigilant Compact Plus Network

A secure network can have up to 31 control panels connected in a loop using any one of the recommended network cable.

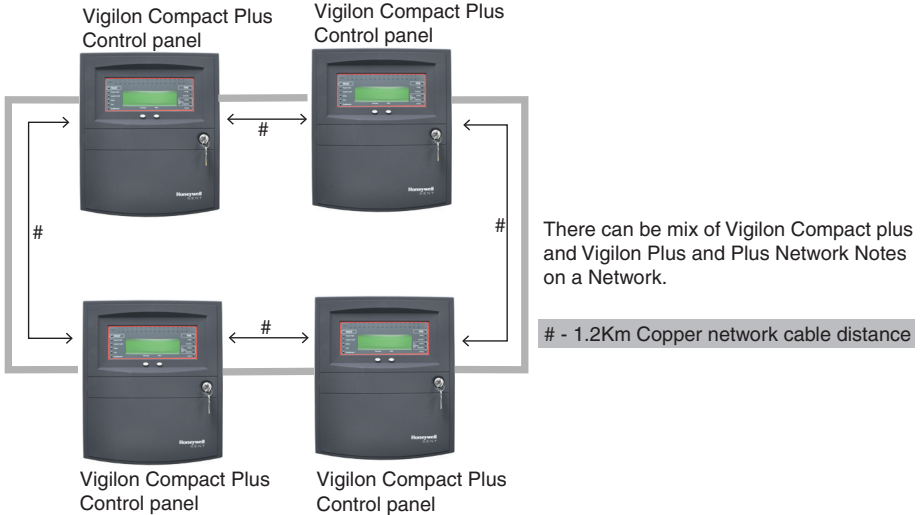

## Network wiring

A secure network can consist of up to 31 control panels and network nodes connected in a loop, communicating on Vigilant 3217 protocol.

N/C = No connection

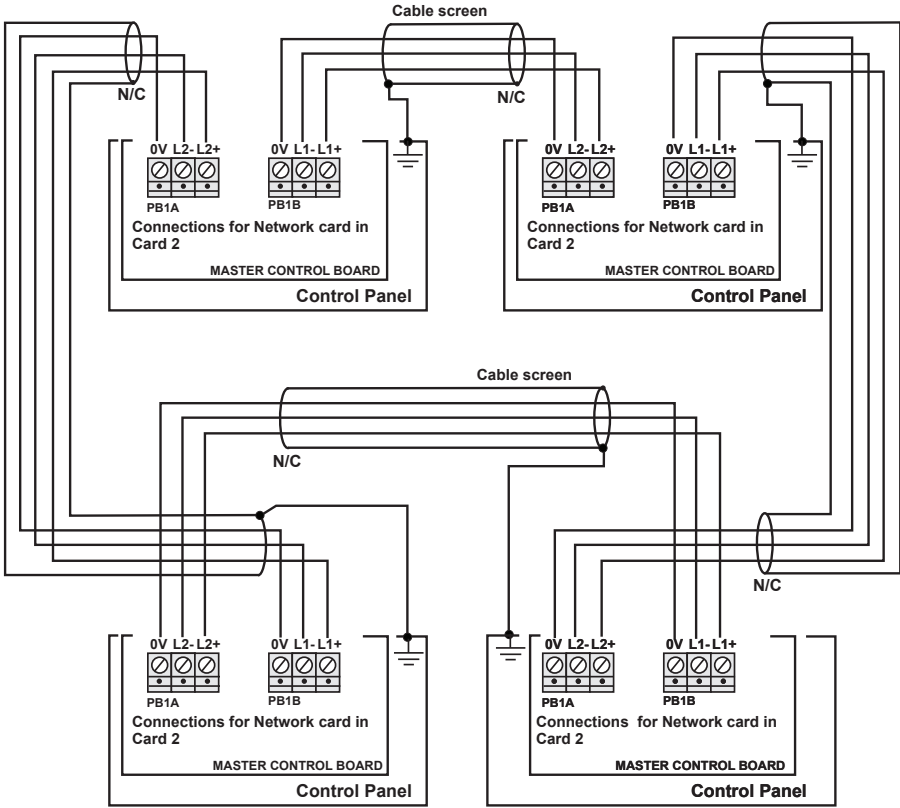

**The cable screen must be connected to an earth terminal in the backbox, as shown.**

Where a multicore cable is being used ensure the unused cores (cores without signal) are connected to 0V.



**When using a cable having 2 pair with screen, use 1 pair for 0V and use the other pair for L - and L+ connections.**

### Network card and connections

The Network card has the terminals for network cable connection. The Network card is fitted during system commissioning.

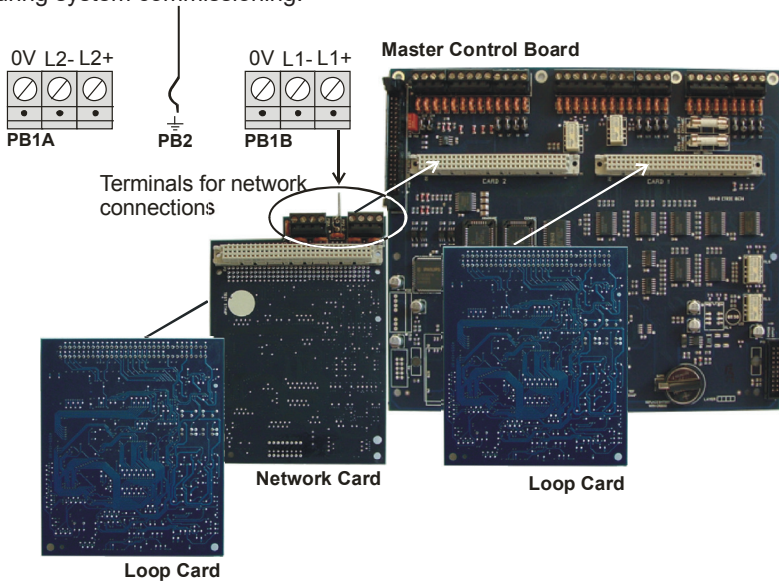

### Network cable screen continuity

Ensure a good screen continuity joint exist where there is a split cable.



**DO NOT mix cables of different types on the same leg of a network as this will create impedance imbalance and disruption to data communication.**

**NOTE:** The cable screens are not connected to earth at the joint or at Panel 2.

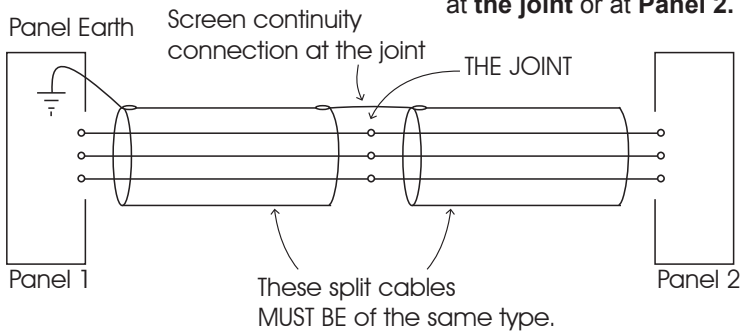

## How to minimise cross talk



**When using standard MICC cable in a network, the different legs of the cable must not be closely placed together, as this will cause signal crosstalk which results in communication failure.**

There are three practical ways of overcoming the crosstalk problem:

- ▣ use a twisted-core MICC cable
- ▣ put a ferrous screen between the cables (ie in the two runs of steel conduit)
- ▣ maintain a distance between the network cables of at least 50mm

On completion of panel installation

## On completion of panel installation

On completion of cable installation ensure the earth lead between the backbox and inner door is fitted. Also the inner and outer doors are closed.

- a. Close the inner door using a screw driver.
- b. Fit the outer door on to the main enclosure.
- c. Close and lock the outer door.

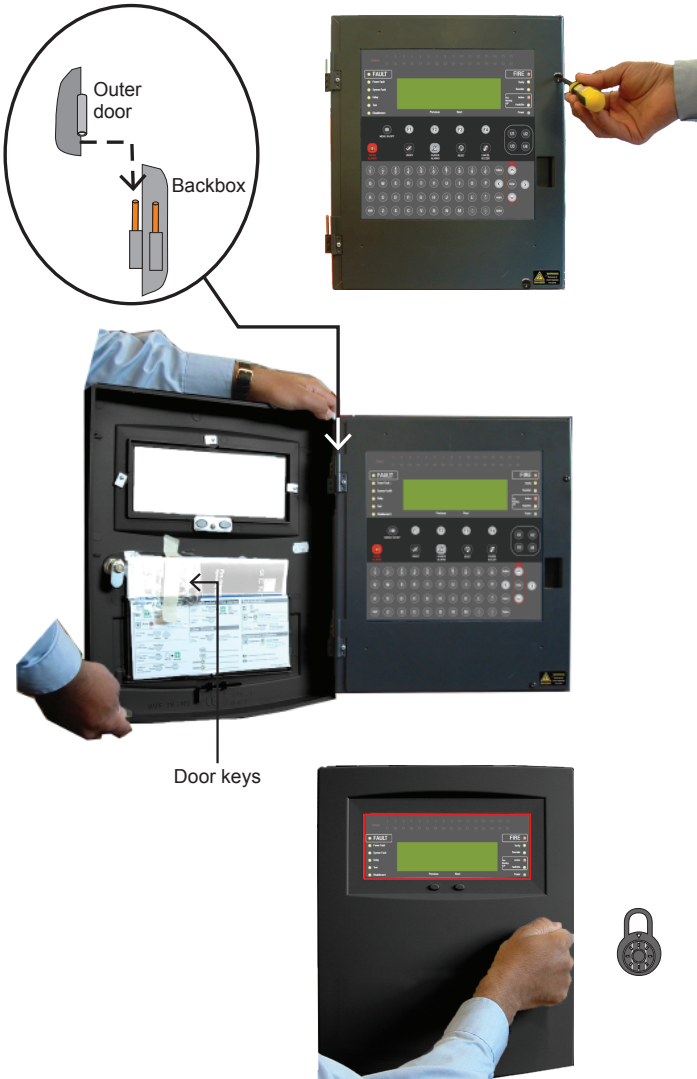

## Other wiring

### FARE wiring requirements

Fire Alarm Routing Equipment (FARE) is also referred to as Fire Routing Equipment (FRE).

The Loop Interface Unit that is used for FARE application must be mounted outside the FARE enclosure. Ensure the external wiring recommendation are followed for compliance.

For information on how to install a Loop Interface Unit see the instructions supplied with the Unit, also refer to instructions supplied with the FARE.

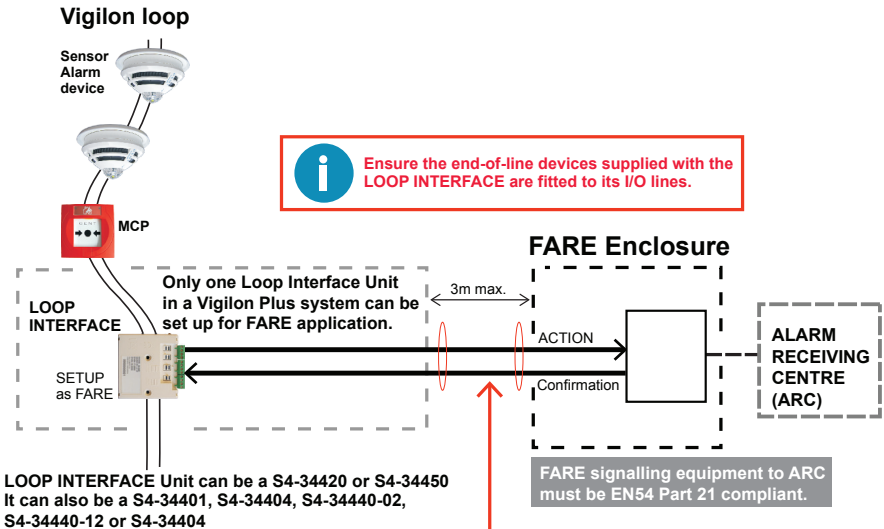

Ensure the end-of-line devices supplied with the LOOP INTERFACE are fitted to its I/O lines.



Where LOOP INTERFACE and FARE are a distance apart then ensure:

- cables are protected, use PH30 cable or cabling that is not be visible by routing them through conduits
- cable lengths used between FARE enclosure and LOOP INTERFACE can be upto 3 metres maximum.

Where the LOOP INTERFACE is close fitted to the FARE enclosure then the above cable recommendation is not applicable.

## FPE wiring requirements

### Fire Protection Equipment (FPE)

Any Loop Interface Unit that is used for FPE application must be mounted outside the FPE enclosure. Ensure the external wiring recommendation are followed for compliance.

For information on how to install a Loop Interface Unit see the instructions supplied with the Unit, also refer to instructions supplied with the FPE.

#### Vigilon loop

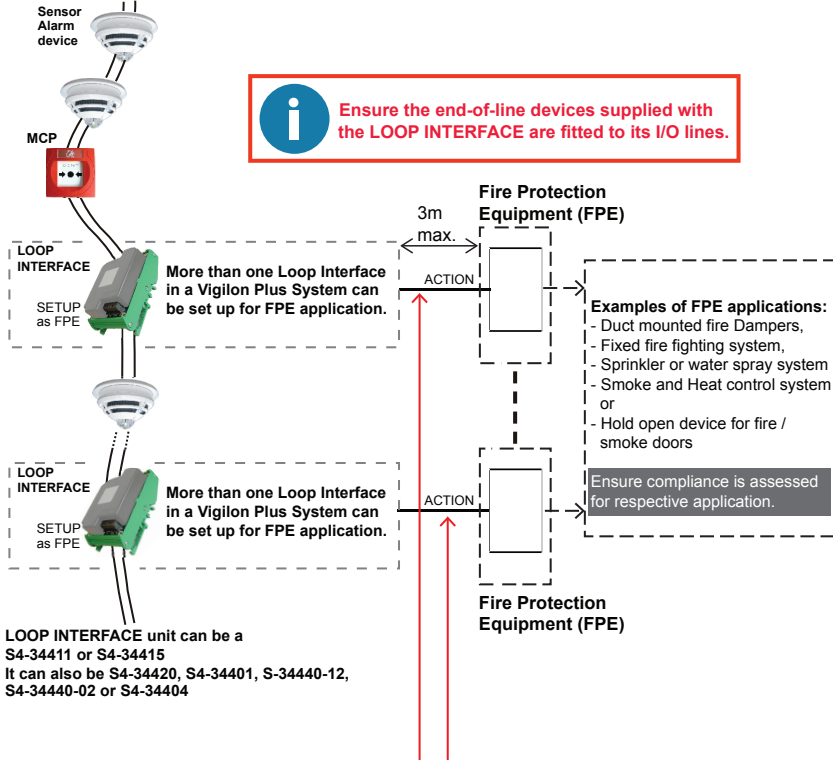

**i** Ensure the end-of-line devices supplied with the LOOP INTERFACE are fitted to its I/O lines.

**i** Where LOOP INTERFACE and FPE are a distance apart then ensure:

- cables are protected, use PH30 cable or cabling that is not visible by routing them through conduits
- cable lengths used between FPE enclosure and LOOP INTERFACE can be upto 3 metres maximum.

Where the LOOP INTERFACE is close fitted to the FPE enclosure then the above cable recommendation is not applicable.

## SAFE System Switch installation

The wiring of a SAFE System switch to an LV Interface unit is shown below. The SAFE System functionality is used to manage fire detection and alarms in an Area.

- Do not test the switch with an insulation tester
- Do not use electric screwdriver or power tool to tighten the product.
- Ensure all wire connections to the switch terminal block are securely fitted.

### Wiring

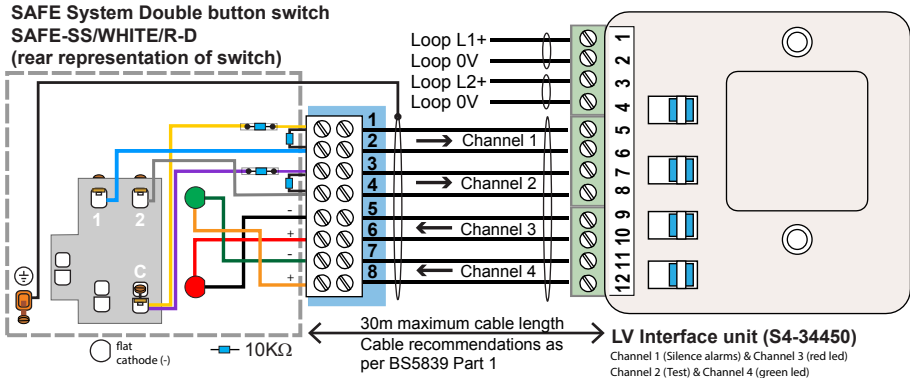

### Backbox

- a. Before mounting the backbox to a wall ensure the backbox is deep enough to accommodate the SAFE System Switch module assembly.
- b. Connect the external cables from the LV interface to the SAFE System Switch as shown. Using the fixing screws supplied mount the SAFE System Switch without the frontplate to the backbox.
- c. To optimise frontplate installation do not overtightened the screws. Make adjustments so that the frame of the SAFE system switch module sit squarely on the wall.

### Frontplate

- a. Locate the top and bottom hooks on the back of the frontplate into the holes on the top and bottom of the module.
- b. Gently push along the top edge of the frontplate followed by the bottom edge and side edges.

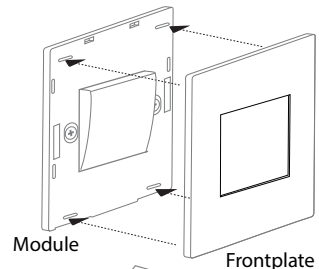

### How to remove the Frontplate if required:

- a. Carefully insert a 4mm flat bladed screwdriver into the slots provided along the bottom edge of the frontplate
- b. Carefully twist the screwdriver and lift the frontplate away disengaging the snap fits.

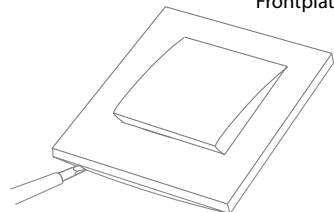

## S-Quad Sensor installation



This following is shortened version of the information on the S-Quad product range, for full information see the S-Quad data sheet (4188-1073 or 4188-779 for legacy S-Quads).

Information on S-Quad Devices can be downloaded from [www.gentexpert.co.uk](http://www.gentexpert.co.uk) by registered users.

### Base

The base has terminals for external cables, for the wiring of loop circuit and monitored input or output circuit. Any S-Quad device can be plugged into an S-Quad base.

### IP21 Base

A IP21 Base Gasket prevent damage from dripping water from the ceiling.

An optional label (Part No: 805576) can be fitted to the base.

Where a label is used it can be marked up with device location information before if is fitted to the Base.

### Indicators

The S-Quad has a red LED that gives an indication in the event of a fire. The LED can be configured to flash periodically, as an 'in operation' confirmation, this indication is given system-wide at all S-Quads. The S-Quad with a CO sensor also has a blue LED to indicate when a fire signal senses the presence of CO.

### Dust Cover

A dust cover is supplied with the S-Quad, to prevent dust from building work contaminating the sensor. The cover is removed prior to the commissioning of the fire alarm system.

## Siting

A S-Quad device plugs into a dedicated Base that is installed in the protected premises. The Bases should be sited in locations as defined by the project plans and by BS 5839 : Part 1 : 2017.

## Do's and Don't



Follow recommendations detailed in section 22 which relates to automatic fire detectors and section 16 which relates to alarm sounders of BS 5839:Part 1 : 2017.

**DO Locate Visual Alarm Devices in accordance with Loss Prevention Council Code of Practice CoP 0001.**

<http://www.redbooklive.com/lps.jsp>

**DO NOT locate smoke detectors where products of combustion may be present such as in kitchens, garages, furnace rooms, welding shops etc.**

**DO NOT locate heat detectors above boilers or heaters or where the temperature is normally very high or liable to sudden fluctuations.**

**DO NOT locate smoke or heat detectors: -**

- In dusty or dirty environment.
- Near heating or air-conditioning grilles.
- Outdoors in stables, sheds etc.
- In excessively damp areas.
- In dead air spaces at the junctions of ceilings and walls.
- At ceiling locations where a 'thermal barrier' may exist.

**DO NOT locate a CO detector: -**

- In buildings where farm animals are kept.
- In excessive damp areas.
- In battery room where non sealed battery are kept.
- In a Car park where exhaust fumes will be present.

## Metal back box

A metal back box must be used for surface or semi-flush mounting. The earth continuity must be maintained throughout the whole loop. The earth must be securely connected to the back box.

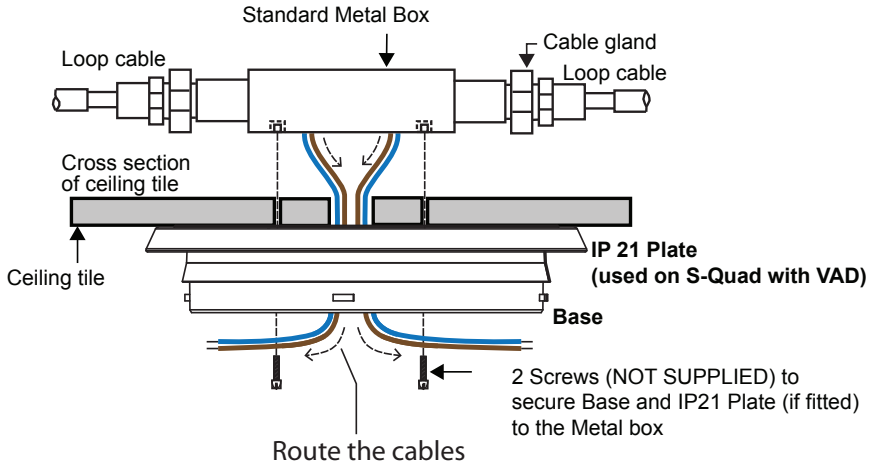

## In - Out wiring to S-Quad bases

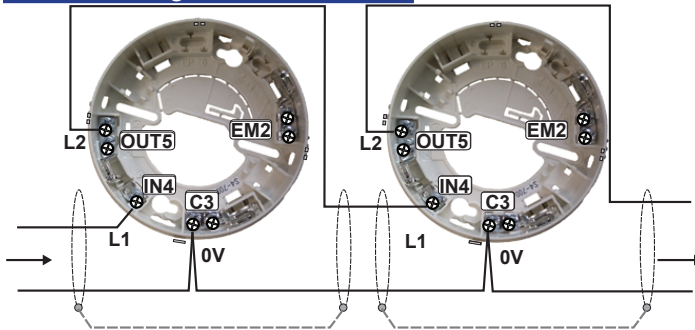

## Programmable input/output

All S-Quad devices can be configured as either monitored input or unmonitored output. The factory setting of the programmable input / output is set as an unmonitored output, to drive an external repeat LED without a series resistor. There is a maximum cable length limit of 15 metres from the S-Quad base to the external I/O Unit.

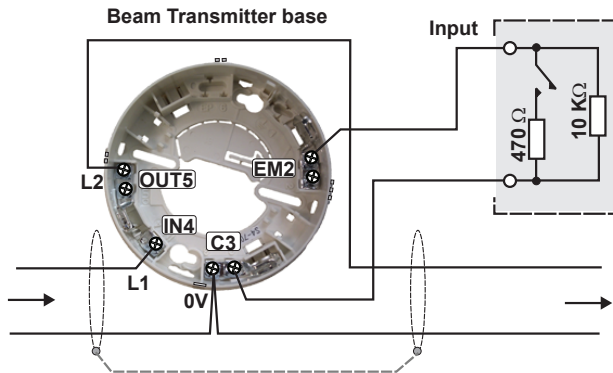
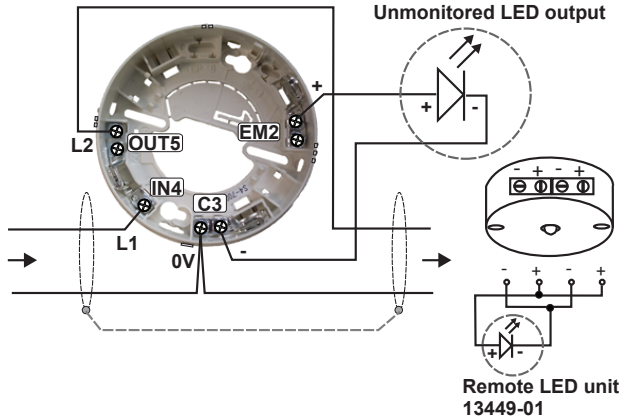

The input can accept signals such as fire, non fire or fault, these are configured during commissioning. As a fire input it is possible to connect a conventional Manual Call Point (non UK application only) with a series resistor of value 470 Ohms coupled with an end-of-line 10Kohms resistor. In this case the fire input is fully monitored for open or short circuit faults.

The input can be setup as a non-fire or fault input using a similar arrangement with series and parallel resistors as shown. It is possible for such an input to trigger a command that is configured to action an output elsewhere in the system to control plant equipment such as ventilation system in a building.

## Tools for S-Quad

An extractor tool allows removal and fitting of the S-Quad device head into the base. By fitting a screw-on adaptor, the tool can also be used to remove the sensor dust cover.

### To remove an S-Quad

Fit the tool onto the S-Quad. Turn S-Quad anticlockwise until it stops and remove the S-Quad from the base.



### To fit an S-Quad

Fit the S-Quad on to the tool. Offer S-Quad to base and rotate clockwise until it moves upwards in to the base and rotate it again until it clicks and goes no further, the lines on the base and S-Quad will align.



### To fit a dust cover

Place the dust cover onto the tool inside the cradle. Offer the cover to the S-Quad, locate and push to fit it onto the assembly. Withdraw the tool when the dust cover is in place.



### To remove a dust cover

A dust cover remover tool must be fitted to the main tool to extract the dust cover. Press the pad of the dust cover remover tool onto the dust cover, this creates an air tight grip, to allow the cover to be pulled off from the S-Quad.



## Vigilon Compact Plus parts

This section lists parts associated with the Vigilon Compact Plus panel. For further information on the availability of the parts contact your supplier.

### Control Panels

**COMPACT-PLUS** *Vigilon Compact Plus control panel  
c/w 1 - Loop card (2-12V 12Ah batteries for 24hr standby - supplied)*

### Accessories

**COMPACT-NC** *Network card for COMPACT-PLUS*

**COMPACT-FLUSH** *Flush surround (for COMPACT-PLUS)*

**COMPACT-FLUSH-SS** *Flush surround stainless steel (for COMPACT-PLUS)*

**VIG-RPT-DOOR-SS** *Stainless steel door (for COMPACT-PLUS)*

**VCS-ODDOR-PLUS** *Compact 24hr outer door assembly (for COMPACT-PLUS)*

**VCS-IDOOR-PLUS** *Compact 24hr inner door assembly (for COMPACT-PLUS)*

**4015-514-Y** *12V 12Ahr Battery*

**COMPACT-LPC-EN** *Loop Card (EN54) up to 2Km*

**VCS-PSU-N** *PSU (for COMPACT-PLUS)*

**VCS-MCB-PLUS** *Master Control Board (for COMPACT-PLUS)*

### Printer

**PRINTER-HAND** *Handheld serial thermal printer*

**PRINTER-H-PAPER** *Thermal paper for handheld printer*

### Manuals

**4188-1101** *Vigilon Compact Plus panel - Operating instructions*

**4188-749** *Log book*





 **At the end of their useful life, the packaging, product and batteries should be disposed of via a suitable recycling centre and in accordance with national or local legislation.**

 **WEEE Directive:**  
At the end of their useful life, the packaging, product and batteries should be disposed of via a suitable recycling centre.  
Do not dispose of with your normal household waste.  
Do not burn.

<b>UK CA</b> 0832	<b>CE</b> 2831
<b>Honeywell Gent</b> <b>Manufactured by: Honeywell Life Safety Systems-Romania</b> <b>Street: Str. Salcamilor 2 bis- Lugoj</b> <b>17</b>	
DoP 131-CPR-2017 131-CPR-2017 131-CPR-2017	Product No. COMPACT-PLUS COMPACT-PLUS-PO COMPACT-PLUS-SP
EN54-2: 1997 + A1:2006, EN54-4: 1997 + A1: 2002 + A2: 2006	
COMPACT-PLUS COMPACT-PLUS-PO COMPACT-PLUS-SP	(EN54-2 & 4) (EN54-2 & 4) (EN54-2 & 4)
<b>Intended for use in fire detection and fire alarm systems in and around buildings</b>	
Refer to DOP 131-CPR-2017 for level or class of performance declared, for details see website <a href="http://www.gent.co.uk">www.gent.co.uk</a>	

Honeywell Gent reserves the right to revise this publication from time to time and make changes to the content hereof without obligation to notify any person of such revisions of changes.

<b>Honeywell</b> GENT	Honeywell Building Technologies, Building 5 Carlton Park, King Edward Avenue, Narborough, Leicester, LE19 0AL		Website: <a href="http://www.gent.co.uk">www.gent.co.uk</a>
	Telephone: +44 (0) 203 409 1779	Technical support: <a href="http://www.gentexpert.co.uk">www.gentexpert.co.uk</a>	